



**Metrotile Viksen**

**Metrotile**<sup>®</sup>  
worldwide roofing systems

**The chaotic structure of hand-split wooden shingles**

The inspiration for the **Metrotile Viksen** is to be found in the uniqueness of the ancient Viking architectural style. Used in building construction, their homes and other edifices were built entirely from wood, onto which small roof shingles were then applied extensively.

The hand-split wood pattern is smaller than the wood pattern of the actual Shake profile, thus imparting an individual and rustic character to each building.

Metrotile Viksen is a stone-coated panel pressed from a high grade of Aluzinc<sup>®</sup> coated steel or similar/equivalent protective layer and is available in a wide selection of colours to enhance any exterior colour scheme.

**PRODUCT  
QUALITY  
100%  
GUARANTEED**

*Weatherproof  
guarantee  
of a  
lifetime*



# Metrotile Viksen

Lightweight high grade steel with Aluzinc® or equivalent coating for incredible strength and resistance. Suitable for all roof shapes.

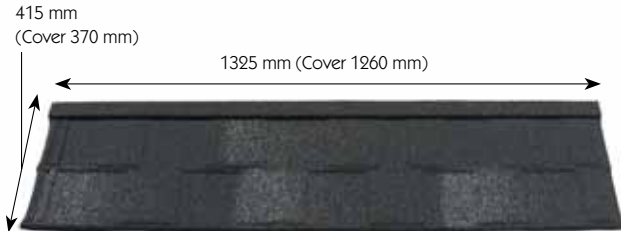

## Specifications

Minimum pitch	15°
Maximum pitch	90°
Size of tile - overall*	1325 x 410 mm
Size of tile - cover*	1260 x 370 mm
Gauge of steel**	0,45 mm <sup>2</sup>
Linear cover width*	1260 mm
Coverage*	0,464 m <sup>2</sup>
Weight per m <sup>2</sup> *	6,47 kg
Weight per tile*	3,0 kg

\* The measurements and the weight may vary slightly by the finish that is added to the panel.  
\*\* Steel thickness according to the EN 10346.

## Standard colours

A wide range of colours are available to help you express your individuality.

### Granules finish

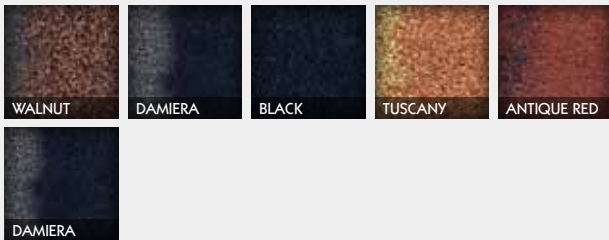

Metrotile offers even more special colours to modify the looks of your roof even more to your taste. Ask your dealer for more information about the non-standard colours.

## Properties



### Fire proof

Conform with the European standards

### Strong

Exceptional strength and resistant to damage

### Stable

Resistance to extreme wind or earthquakes

### Durable

Color stability and protects against UV light

### Lightweight

Light and easy to handle and install

## Installation of the tiles

The roof panels can be interlocked either right over left or left over right with the side laps of one small corrugation.

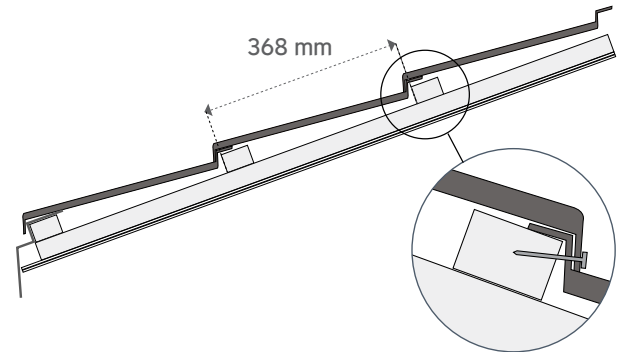

The panels are placed onto battens spacing 368 mm.

The downturned front edge and the upturned rear edge of each tile provides a strong, weatherproof, overlapping and interlocking roof covering. Each panel is secured by 3 nails in the front downturned edge into the side of the batten, positioned out of the water course.

Each panel or accessory can be cut or bent in the shape of the roof. It is important to use tools recommended by Metrotile.

## Accessories

Metrotile offers a broad choice of accessories that fully integrate with the Metrotile Viksen profile.

- **Ridges, junctions and end caps.**  
For use on ridges and hips in angle, square, rounded shape.
- **Barges, flashings and finishings.**  
For roof covering at foot, gables, verges, barges, against walls.
- **Other accessories.**  
Like ventilation systems, roof windows, light tubes, integrated solar panels, clear tiles,...
- **Installation equipment.**  
Everything you need for installation: nails, benders, guillotines,...

For a complete and detailed list of accessories and more information regarding the installation of a Metrotile roof, contact your dealer.